

METAL-FACH

OPERATION INSTRUCTIONS

Automatic bale wrapper

Z593-0E



Issue: 01

Year of issue: 2014

The original operating manual language is Polish.

Original Instructions



Thank you for choosing our Z593-0E automatic bale wrapping machine designed for efficient operation.

The following manual will let you fully use the advantages of our wrapping machine and to optimise the bale wrapping process.

The manual contains a detailed table of contents followed by descriptions which will allow to easily identify the device and to make the best use of it.

The information regarding safety and comfort of operation, description of coupling with a tractor, operation during work, technical service activities and storage conditions are listed on the following pages of the manual.

A spare parts catalogue containing the list of the wrapping machine major components allowing for easy ordering is attached to the manual in a digital form on a CD.

A printed version of the catalogue may be purchased at authorised dealers or directly from the manufacturer.

Both the manual and the spare parts catalogue contain basic information on the product. The elements fitted to the equipment may be slightly different from the ones presented in the manual.

The manufacturer reserves the right to introduce changes without notice.

Contents

1	Wrapping machine identification, general safety rules	4
1.1	Wrapping machine identification.....	4
1.2	Wrapping machine construction	6
1.3	Wrapping machine characteristics.....	7
1.4	Bale wrapper's hydraulic system.....	8
1.5	Wrapping machine dimensions.....	9
1.6	Symbol placement.....	10
1.7	Warning symbols.....	11
1.8	General safety rules.....	12
2	Drive operation.....	14
2.1	Coupling with drive.....	14
2.2	Disconnecting from the drive	15
3	First start-up	15
4	Controls and operation of wrapper.....	16
4.1	Description of buttons on the ARASO-V1 control panel	16
4.2	Operating the control panel	18
4.2.1	Activating the panel.....	18
4.2.2	Powering off the panel	18
4.2.3	Collision protection	18
4.2.4	Wrapper manual control	20
4.2.5	Semi-automatic mode operation	20
4.2.6	Automatic operation	21
4.2.7	Transport position	21
4.2.8	Stop during wrapping	23
4.2.9	Emergency stop	23
5	Ongoing adjustments	24
5.1	Correcting sensor settings.....	25
5.2	Adjustment of bale on end kit support	26
5.3	Adjustable hydraulic valves	28
5.4	Towbar position change	29
5.5	Installing film	30
5.6	Adjustment of driving chain	31
5.7	Film cutter	31
6	Wrapping.....	32

6.1	Wrapper preparation	32
6.2	Bale loading	32
6.3	Wrapping	33
6.4	Unloading a wrapped bale	34
6.5	Finishing work.....	35
7	Periodical inspections.....	36
7.1	User inspection.....	36
7.2	Service checks.....	36
8	Authorised service.....	37
8.1	Warranty service	37
8.2	Ongoing maintenance	37
8.3	Ordering spare parts.....	37
9	Transporting the bale wrapper	37
9.1	Transporting a load	37
9.2	Driving on public roads.....	38
10	Bale wrapper storage	39
11	Hazards	40
11.1	Description of residual risk.....	40
11.2	Assessment of residual risk	40
12	Bale wrapper disposal	41
13	Typical problems and troubleshooting.....	41
14	Accessories	42
15	Names and abbreviations.....	43
	Warranty card.....	44

1 Wrapping machine identification, general safety rules

1.1 Wrapping machine identification

The wrapping machine is identified by its nameplate securely fastened to the main frame of the machine.



Fig. 1. The information presented on the nameplate is shown on the diagram below.

Caution!

It is forbidden to drive the machine on public roads without its nameplate or with an illegible nameplate.



Fig. 2. Nameplate location.

When purchasing the machine check the serial number indicated in the Manual and the warranty sheet against the serial number stamped on the nameplate.

The Manual is a part of the Z593-OE wrapping machine equipment.

If the machine is sold to another user, it must be supplied with the operating manual. It is advised that the supplier has a confirmation stating that the manual was transferred together with the machine, signed by the buyer and filed.

Carefully read the operating manual.

If the rules stated in this manual are complied with, it will help prevent hazards and operate the machine efficiently; it will also allow to retain the warranty throughout the period granted by the manufacturer.

Detailed information on the structure, operating principles, technology and other details may be obtained from authorised outlets and the wrapping machine manufacturer.

Caution!

It is forbidden for persons who have not read the manual to operate the machine.

The wrapping machine shall be operated according to its intended use by coupling it with a tractor with nominal power exceeding 30 kW and towing power class of 0.9. The Z593-0E bale wrapping machine is designed to pick up bales from the ground, wrap them in film and unload to the ground.

Dry grass and other papilionaceous plants with humidity of approx. 60%¹ shall be rolled into bales using the collecting and wrapping presses. The bale wrapping process should be conducted on the field or in the storage yard practically immediately after they have been rolled (up to 2 hours²). The wrapped bales should be stacked in up to two layers on a dry and even surface making sure the wrapping film is not torn.

The fermentation process must continue for 6 to 8 weeks at positive temperatures. Thus provided silage is fit for use as a wholesome feed for animals.

During operation, the operator is not subject to noise which may cause the loss of hearing, as the noise level of the machine does not exceed 70 dB (A) and the operator works inside the tractor cabin.

During the operation, the operator is not subject to harmful vibration as the vibration level transferred to the upper limbs does not exceed 2.5 m/s², and the vibration level transferred to the body is lower than 0.5 m/s² and the operator is positioned in the tractor cabin.

Caution!

Any unauthorised changes to the machine structure absolve the manufacturer from all responsibility for the threats and damage it may cause.

¹ *Grass and other papilionaceous plants prepared for ensilage and wrapping should be mowed in the early phase of heading (best done in the afternoon). On the next day, after a few hours of drying, the mowed material should be gathered using the wrapping presses. Maximum bale compression must be maintained.*

² *An unwanted decomposition process takes place in bales left unwrapped for a longer time.*

1.2 Wrapping machine construction

The Z593-0E wrapping machine consists of the following units:

- Complete axle with ground wheels item 1
- Lower frame item 2
- Rotary frame item 3
- Loading arm item 4
- Unloading unit item 5
- Drawbar item 6
- Wrapping film feeder item 7
- Support stand item 8
- Cutting assembly item 9
- Wheel lock wedge item 10
- Side wheel item 11
- Hydraulic control unit item 12
- Control unit item 13
- Electronic control panel item 14

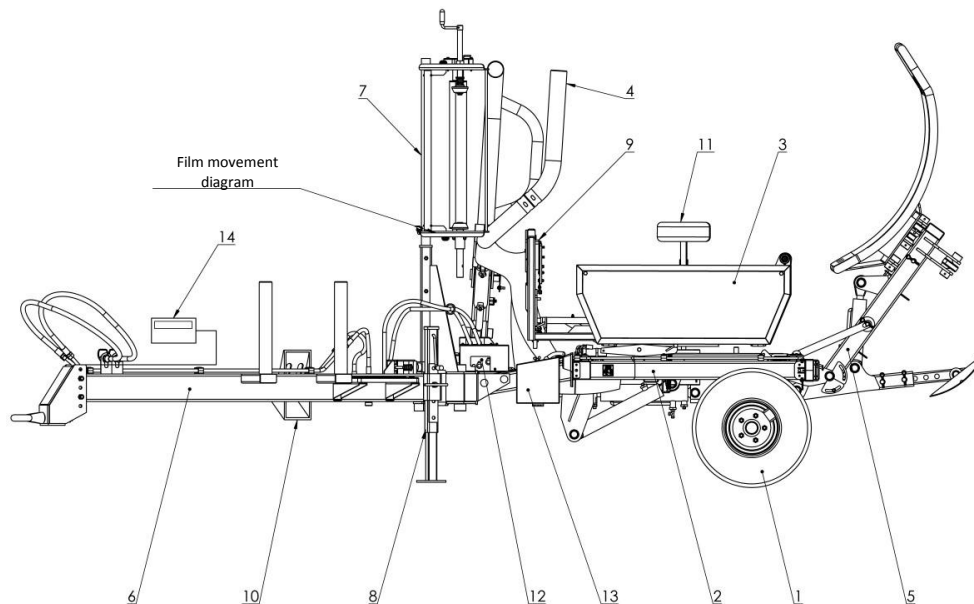

Fig. 3. Wrapping machine construction.

The drawbar (6) is attached to the bottom frame (2) and equipped with an adjustable hitch ring for the connection of the wrapping machine to the tractor and its levelling for a working or transport position.

A rotary frame (3) is attached to the bottom frame (2). The loading arm (4) and the bale unloading unit (5) are mounted to the bottom frame (2) in a movable way. The film feeder (7) is attached to the bottom frame (2). A pictogram presenting the film movement during the wrapping machine operation is placed on the film feeder.

1.3 Wrapping machine characteristics

No.	Description	Measure unit	
1	Type		Z593-0E
2	Coupling method with the tractor		Hitched
3	Undercarriage type		Mono-axial
4	Overall dimensions in the working position Length/width/height	mm	6050/3000/2600
5	Overall dimensions in the transport position Length/width/height	mm	5220/2390/2600
6	Machine weight	kg	1250
7	Maximum bale weight	kg	800
8	Wrapped bale dimensions Length Diameter	mm	1200 1000-1200
9	Maximum service speed	km/h	10
10	Maximum transport speed	km/h	15
11	Coupling with a tractor by	-	Agricultural hitch
12	Tractor class	-	0.9
13	Minimum tractor power output	kW	30
14	Required pressure in the tractor power hydraulic system:	MPa	14
15	Recommended tractor pump output	l/min	min. 22
16	Hydraulic oil cleanliness	-	not lower than 8 in accordance NAS 1638 (category 19/17/14 in accordance ISO 4406-1996)
17	Tractor hitch load	kN	1.2
18	Wheel track	mm	2000
19	Tyres	-	26.5x14.00-12
20	Tyre pressure	bar	1.7
21	Tow bar hitch-ring diameter	mm	40
22	Wrapping machine drive	-	Hydraulic, from the tractor power hydraulic system
23	Rotary frame drive	-	Hydraulic motor
24	Maximum rotational speed of the rotary frame	RPM	35
25	Bale loading method	-	Automatic, using a loading arm
26	Bale unloading method	-	Automatic with the unloading unit
27	Film cutting	-	Automatic during unloading
28	Film width	mm	500; 750
29	Number of the rotary frame (table) revolutions using film: 500 mm 750 mm	revs.	24 16
30	Bale wrapping time (loading, wrapping, unloading)	min	2
31	Number of operators	-	1 (tractor driver)
32	Control panel	-	Electronic, type ARASO-V1
33	Electrical system voltage	V	12
34	Machine lights	-	Following the requirements of the traffic code

1.4 Bale wrapper's hydraulic system

The wrapping machine's hydraulic system is powered from the tractor hydraulic system. To attach the machine to the tractor hydraulic system, the attachment cables are connected to the hydraulic controls and further to the wrapping machine's hydraulic motor and hydraulic actuators. The hydraulic motor uses chain transmission to drive turntable which in turn uses intersecting axis gear to drive drums onto which a silage bale is being loaded. The purpose of double-acting actuators:

- Tilting the turntable and the unloading unit to the vertical and horizontal positions;
- Lifting and lowering the loading arm.

The Z593-0E bale wrapper is equipped with a power hydraulic system (fig. 4.) which includes the following elements:

- | | |
|---------------------------------------|---------|
| • flow controller | item. 1 |
| • electrically-driven hydraulic block | item. 2 |
| • three-way electric valve | item 3 |
| • throttle-check valve | item 4 |
| • hydraulic motor with brake | item. 5 |
| • protective valve for loading arm | item 6 |
| • loading arm lifting actuator | item 7 |
| • loading arm grip actuator | item 8 |
| • turntable frame tipping actuator | item 9 |
| • bale on end kit actuator | item 10 |
| • cradle actuator | item 11 |

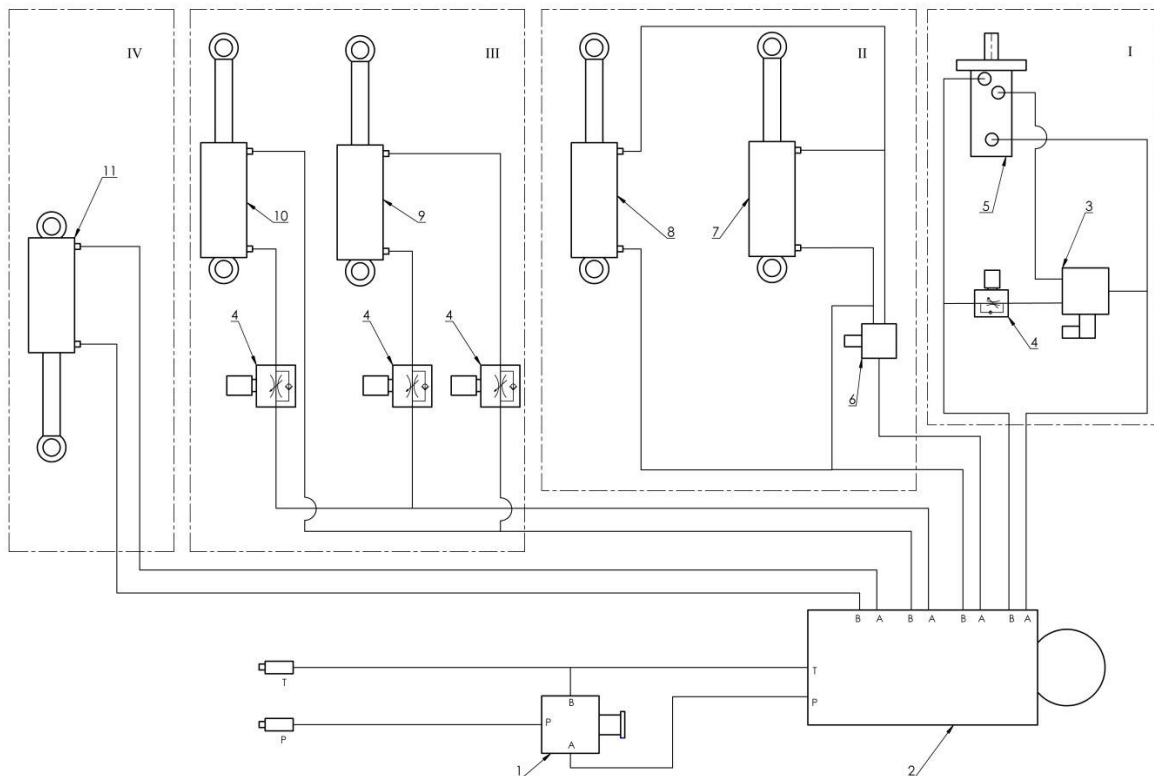

Fig. 4 Wrapper hydraulic system.

- Section I — Turntable
- Section II — Loading arm

- Section III — Turntable frame and bale on end kit frame
- Section IV — bale on end kit cradle

Engine and hydraulic actuators are controlled using an electronic control panel located inside the tractor operator's cabin. The panel is coupled with the control module via **D-sub DE-9** type cable which directly controls solenoid valves in the hydraulic block.

The 4-sectional control unit (1) is protected against high pressure from the hydraulic system by means of a safety valve.

The bale wrapper's hydraulic system is protected against excessive volume output from the tractor's power hydraulic system by means of a flow controller.

1.5 Wrapping machine dimensions

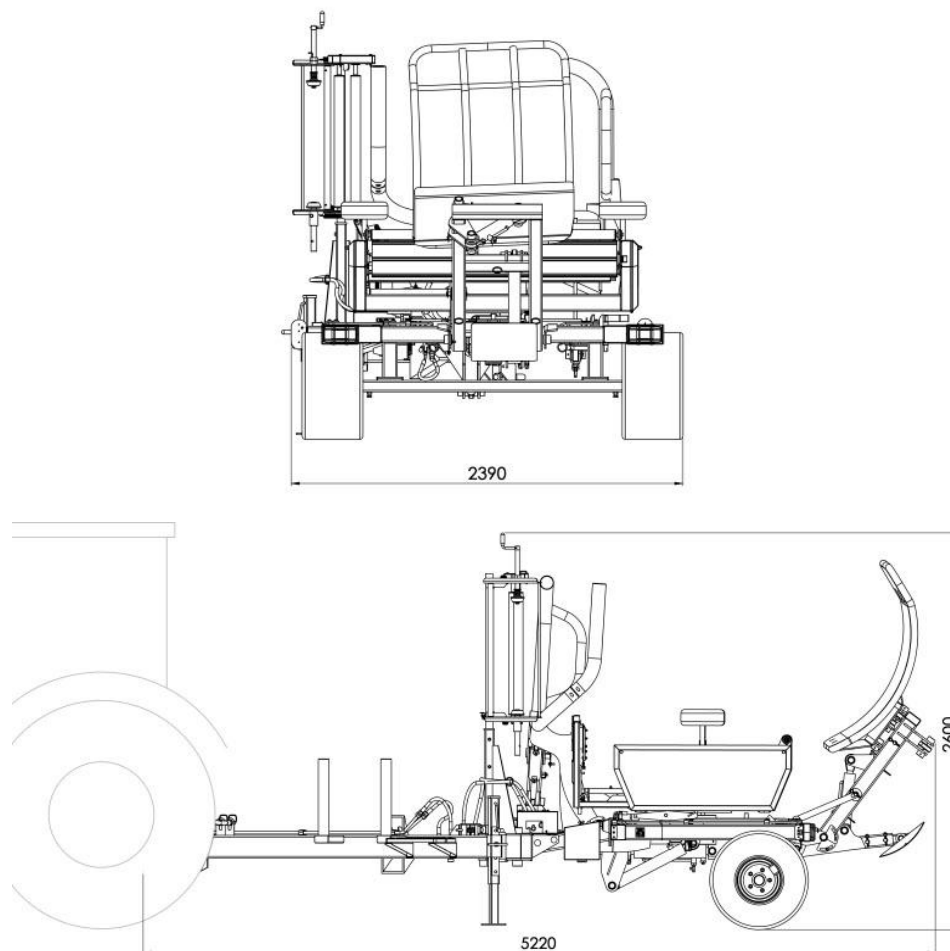

Fig. 5. Overall dimensions of a bale wrapper in the transport setup. The dimensions of the machine in a working position are given in table: **Bale wrapper properties** chapter 1.3 of the manual.

1.6 Symbol placement

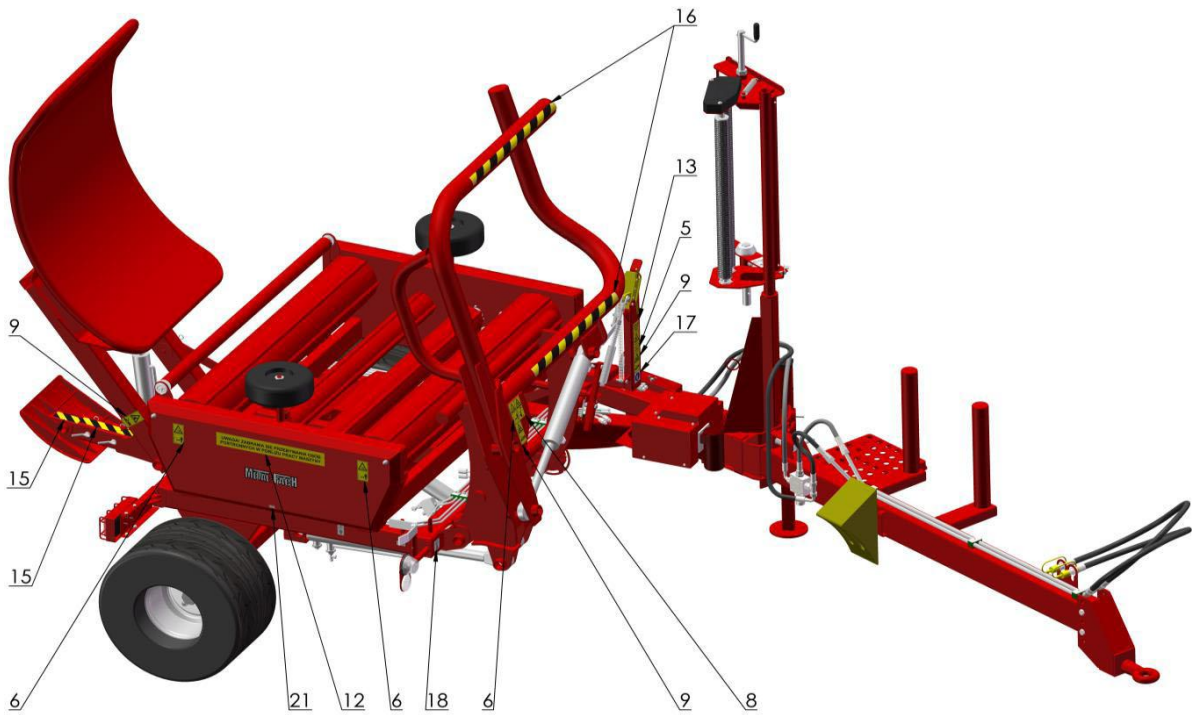

Fig. 6. Location of symbols – right side. The meaning of pictograms is explained in section 1.7 of the Manual.















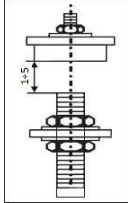





Fig. 7. Location of symbols – left side. The meaning of pictograms is explained in section 1.7 of the Manual.

1.7 Warning symbols

The warning pictograms placed on the machine (chapter 1.6) inform the operator about the hazards and dangers which may occur during work. Keep the symbols clean and legible.

Replace illegible symbols with new ones, available from the manufacturer.

 <p>Symbol 1 Refer to the operating manual before performing this action.</p>	 <p>Symbol 8 Danger zone. Install a support before starting maintenance activities.</p>
 <p>Symbol 2 Turn off the engine and remove the ignition key before servicing or repairs.</p>	 <p>Symbol 9 Danger of crushing.</p>
 <p>Symbol 3 Do not stand near the pull rods of an operating wrapping machine.</p>	 <p>Symbol 10 Avoid contact with liquids under pressure.</p>
 <p>Symbol 4 Do not open or remove the safety guards during machine operation.</p>	 <p>Symbol 11 Do not stand on ladders and platforms while the tractor is moving.</p>
 <p>Symbol 5 Do not touch rotating elements during the machine operation.</p>	<p>UWAGA! ZABRANIA SIĘ PRZEBYWANIA OSÓB POSTRONNYCH W POBLIŻU PRACY MASZYNY</p> <p>Symbol 12 Warning label.</p>
 <p>Symbol 6 Do not approach the working machine. Danger of being crushed by a bale.</p>	<p>UWAGA! OSTRY NÓŻ</p> <p>Symbol 13 Warning label.</p>
 <p>Symbol 7 Keep a safe distance from the raised arm. Danger of being crushed.</p>	 <p>Symbol 14 40 x 950 warning sign.</p>

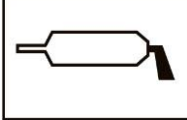
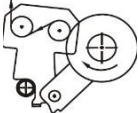
 Symbol 15 50 x 300 warning sign.	 Symbol 20 Correct location of a sensor in front of actuator.
 Symbol 16 40 x 800 warning sign.	 Symbol 21 Recommended wrapping machine tire pressure.
 Symbol 17 Use protective gloves during maintenance operations.	 Symbol 22 CE requirements conformity symbol.
 Symbol 18 Attachment points for loading on a means of transport.	 Symbol 23 Lubrication point.
 Symbol 19 Film wrapping diagram.	

1.8 General safety rules

- 1) During operation and repair of the wrapping machine the farming health and safety regulations contained in the Regulation of the Minister of Agriculture and Food Economy of 12 January 1998 must be complied with.
- 2) Only an adult with a valid agricultural tractor driver's licence and familiarised with the occupational health and safety regulations regarding agricultural equipment and this Manual may operate this machine.
- 3) The following manual must be read and adhered to, paying special attention to directions regarding the safe operation of the wrapping machine.
- 4) The manual indicates the machine parts which pose a potential threat. Hazardous areas are marked with yellow stickers with warning symbols. Pay special attention to the hazardous areas and strictly adhere to the rules.
- 5) The operator must familiarise themselves with the meaning of the symbols.
- 6) It is prohibited to use a wrapping machine without protective covers in place.
- 7) Before every start up of wrapper, check the machine condition, completeness of the machine and the fixing of covers.
- 8) Before every drive, starting the wrapper and driving on public roads, check the correctness of coupling of the machine with tractor, tightening of wheel bolts and correctness of tractor-hitch connection.
- 9) All adjustment, repair and maintenance works shall be conducted with the tractor engine turned off and making sure that the machine is secured against accidental start.
- 10) Before commencing loading and during this process, make sure that there are no bystanders, especially children, nearby.
- 11) During the operation of the wrapping machine, allow for free space near the rotating elements. During bale wrapping, no people or animals are allowed near the rotating elements.
- 12) Exercise extreme caution when working on inclined terrain. Note that the bales may roll down slopes.

- 13) It is forbidden to operate the wrapping machine with any of the assemblies lifted.
- 14) Do not stand between the wrapping machine and the tractor when the tractor engine is running.
- 15) Exercise extreme caution when coupling and uncoupling the wrapping machine with/from the tractor. The machine should be coupled with the tractor equipped with an agricultural hitch able to withstand the vertical load larger than the vertical load on the wrapping machine's drawbar.
- 16) During operation, use appropriate protective clothing and shoes with anti-slip soles.
- 17) Bale wrapping film should be installed after stopping the tractor's engine and protecting the engine against inadvertent start (ignition key removed and service brake applied).
- 18) It is forbidden to operate damaged hydraulic lines. The damaged lines must be immediately replaced with new ones. During the replacement of hydraulic lines, use impermeable protective clothing.
- 19) The machine hydraulic system shall only be operated from the tractor cabin.
- 20) Follow the traffic code regulations and the manufacturer's recommendations when travelling on public roads.
- 21) Visually inspect the machine being transported before entering a public road.
- 22) It is forbidden to remain on the wrapping machine during transport and operation.
- 23) It is forbidden to carry bales of swath or silage on the wrapper during transport on public roads.
- 24) It is forbidden to operate the wrapping machine while under influence of alcohol.
- 25) It is forbidden to operate the wrapping machine while under influence of drugs or medicines with similar effects.
- 26) It is forbidden to operate the wrapping machine while under influence of medicines which affect the ability to drive vehicles or reduce psychophysical fitness or cause concentration disorders and delay reaction time.
- 27) It is forbidden to drive the wrapping machine near sources of open flame.
- 28) It is required to strictly adhere to the fire protection regulations and immediately extinguish any fire which may occur during the wrapping machine use or at its standstill.
- 29) Eliminate fire sources using powder fire extinguisher.
- 30) Do not approach the working wrapping machine with open flame and do not smoke near the machine.
- 31) Every time before commencing work, check if the tractor is equipped with a dry powder extinguisher. If not, place a dry powder fire extinguisher on the tractor.
- 32) In case of emergency, press STOP button on the control panel. Turn off the tractor engine, remove the ignition key and engage the tractor parking brake. Locate the fault and fix it or have an authorised service point repair it.

2 Drive operation

2.1 Coupling with drive

The Z593-0E bale wrapper should be coupled with agricultural tractors with minimum 30 kW power and 0.9 draw class with two power hydraulic system connection.

- The wrapper shall be coupled to the tractor's lower hitch which allows the transfer of vertical maximum vertical load of 1.2 kN.
- Make sure that there are no bystanders, especially children, in the coupling area.



Caution!

During coupling the equipment to the tractor, place the wrapper in the tractor axis on hard, flat and level ground. Turn off the tractor engine, remove the ignition key and engage the tractor parking brake. Level the wrapper by selecting the appropriate adjustment opening in the hitch.

Caution!

Couple the hitch-ring only with the tractor's hitch and check whether the machine is properly connected and secured against accidental disconnection.

Caution!

Make sure that the tractor hydraulic system is tight.

- Connect the electric supply. Secure the plugs of electric harness against accidental disconnection. Secure against accidental damage.
- Check if the electric and signalling systems work properly.
- Connect the hydraulic power source.
- Reposition the drawbar from transport position to working position (chapter 5.4).
- Remove the protective device from the bale on end kit arm.
- Check tightness of bale wrapper's drive wheels pins.
- Check the correct operation of hydraulic systems without bale and without film in manual mode (chapter 4.2):
 - move the loading arm in manual operation mode, maximum lifting and lowering height of the arm,
 - make couple of revolutions with the turntable moving slow and fast. Stop the table at the unloading position (table drums in parallel to the front beam of the main frame),
 - perform unloading, move the bottom frame of the turntable to the position of maximum deflection. Next, lower the turntable,
 - move and lower the bale on end kit's cradle,

Check the correct operation of power hydraulic systems without bale and without film in semi-automatic mode (chapter 4.2):

- load the machine in semi-automatic mode.
- make 10 revolutions with table in semi-automatic mode (first, set the number of revolutions on the control panel). The table shall move in counterclockwise direction, starting and slowing down should be smooth. The table should stop after making the

preprogrammed number of revolutions and stop at the unload position. If not, manually set the table to the correct stop position using slow movements.

- unload the machine in semi-automatic mode.

If the hydraulic and control systems work correctly, load the first bale and make sure if the load on the tractor's front axle is larger than 20% of the tractor's weight. This is manifested by full steering quality of the tractor.

2.2 Disconnecting from the drive



- Make sure that there are no bystanders, especially children, in the coupling area.
- Place the wrapper on a hard, flat, level ground at the storage location. Turn off the tractor engine, remove the ignition key and engage the tractor parking brake.
- Disconnect the electric power supply.
- Disconnect the power hydraulic system.
- Lower the main frame support.
- Disconnect the hitch-ring from the transport hitch.
- Make sure that the machine will not move accidentally, if necessary, place chock (included with the wrapper, on drawbar) under the wheel.

3 First start-up

The commissioning of a newly purchased bale wrapper should be performed by the dealer's service representative.

Caution!

Before commissioning, familiarise yourself with the following manual, paying special attention to the fragments regarding the safety of the operator and bystanders.









If there are any doubts regarding safety issues, please contact your sales representative or the manufacturer.













Before each start up of the machine, the control panel shall be installed in the tractor operator's cabin.

4 Controls and operation of wrapper

4.1 Description of buttons on the ARASO-V1 control panel



Button (symbol)	Designation	Function
	STOP	Emergency stop — locks all functions of the wrapper. Unlocked with the F1+F2 combination or by turning off.
	Power switch	Activates the control panel
	SET	Views current time and date
	Plus	Changes/increases the current value
	Minus	Changes/decreases the current value
	Menu	Enters the control panel's menu (selected with F1 and F2 buttons): <ul style="list-style-type: none"> - Resets bale counter - Setting time and date — + and - buttons - Resets all fields counter - Setting the number of wraps (10-99) – + and - buttons - Selects the field (16 fields available) – + and - buttons Confirmation: Enter
	Escape	Exits menu and other locations
	Statistics	Viewing the current wrapper's operational statistics

	Enter	Confirms the entered changes or enters other selection levels (on a menu)
	F1	1 press: Resets the counter of current number of revolutions for a table 2 presses: Resets the current bale status (shows if the bale is placed on the turntable) In automatic mode, selects the operation: - Automatic loading of bale - Automatic wrapping - Automatic unloading of bale Selected with buttons: + and - Confirmation: Enter
	F2	Selecting wrapper's operation mode: - Automatic - Semi-automatic - Transport position. Selected with buttons: + and - Confirmation: Enter
	Table rotation — free movement	Holding the button activates free movement of the turntable.
	Table rotation — fast movement	Holding the button activates fast movement of the turntable. First rotation is slow.
	Tipping the cradle	Pressing and holding the button tips the bale on end kit's cradle.
	Cradle return	Pressing and holding the button returns the cradle to home position
	Tipping the turntable	Press and hold this button to move the turntable frame and lift the bale on end kit (unloading to the bale on end kit's cradle).
	Turntable return	Press and holding this button lowers the turntable frame and the bale on end kit to home position (the bale is located on the bale on end kit's cradle).
	Lifting the loading arm	Press and hold to lift the loading arm (loading a bale on the turntable)
	Lowering the loading arm	Press and hold to lower the loading arm.
	Start/Stop	Starts the automatic or semiautomatic bale wrapping process. Press again during the process to stop.
	Automat/Manual	Activates/deactivates automatic mode. The Start/Stop button is inactive during the process.

4.2 Operating the control panel

The panel is an electronic device for operating the wrapper; it also provides the user with information on the current settings and the condition of the machine.

4.2.1 Activating the panel

1. Insert the wrapper's plug to the tractor's 12 V socket.
2. Connect the panel to control module with **D-sub DE-9 L=10 m** cable.
3. Switch the panel's power switch from 0 to I. The switch is located on the panel's side.
4. If the LED next to the Start/Stop button flashes green then the power status is correct.
5. Turn on the control panel using  button. This starts the communication of the panel with the control module. Wait for approx. 5 s until the communication is completed successfully. If the communication is unsuccessful, check if the cables are connected to the control module correctly.

4.2.2 Powering off the panel

1. Make sure that the operational elements are locked at transport position or at their home positions (loading arm lowered, turntable in parallel to the wrapper's frame, table frame lowered).
2. Power off the panel with  button
3. Disconnect the panel from the power supply by switching the switch on the side from I to 0.

4.2.3 Collision protection

The wrapper is software protected against actions which might collide with the turntable. When you try to perform such a move, a message with the information about incorrect positioning of a work element as well as the solution to make such a move possible.

The turntable movement is impossible:

- when the loading arm is lifted above the non-collision position,
- if the table's frame is not fully lowered,
- if the cradle is not at the home position (lowered).

If the loading arm has been lifted to the maximum height and then lowered to the end, the program will not let the arm lift to the top again. According to the program, after such an operation, there is a bale loaded on the turntable and after the arm is lowered, it can be lifted only to the collision-less position. To enable lifting the arm again, unload the bale or reset the bale status (2xF1 - > Enter).

Caution!

You must not move the turntable if the bale on end kit's arm is in transport position (a protective device against falling of the kit is installed) and the loading arm is lowered!

The wrapper returns to the home position after each full work cycle. The home position refers to a situation when all moving elements of the machine are placed in position ready for work, i.e. loading the next bale. In the home position, the working elements of the wrapper are positioned as follows:

- loading arm is lowered and open,
- turntable positioned in parallel to the front beam of the wrapper's main frame,
- turntable frame lowered, bale on end kit frame horizontal,
- bale on end kit cradle lowered (not tipped)

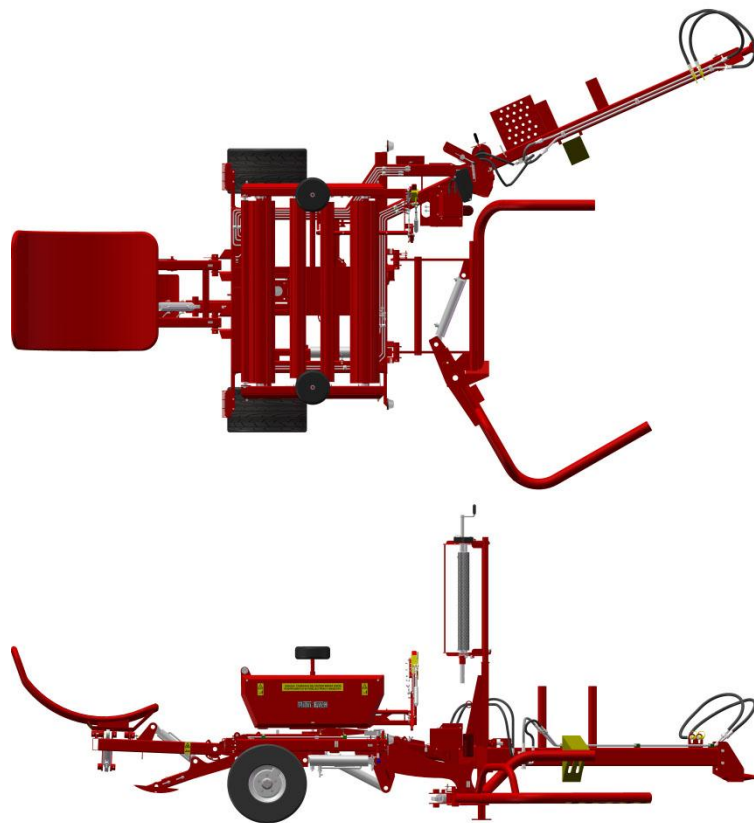

Fig. 8. Bale wrapper in home position.

4.2.4 Wrapper manual control

You can move the working elements of the wrapper using the buttons numbered 1, 2, 3, 4, 6, 7, 8, 9 on the panel. The movement is actuated until you hold a button pressed or until an element reaches extreme position and limit switch activates. The turntable is an exception, it will rotate until a button is released.



When a working unit is placed in a home position, the LED over the button assigned to this unit lights green. When a working unit is in the extreme open position (loading arm lifted, turntable frame tipped, cradle tipped), the LED over appropriate button lights red. In order to move the turntable, the diodes over buttons 2, 3, 4 must light green. If the LEDs are off, the unit is placed in an incorrect position.

The diodes over the turntable movement buttons (1 and 6) are the only exceptions. These diodes light up when the turn number sensor is activated during movement.

4.2.5 Semi-automatic mode operation

In the semi-automatic mode, after an automatic loading you must confirm the readiness for automatic wrapping with the **Start/Stop** button. After wrapping is completed, press this button to confirm that the system is ready to automatic unloading of a bale.

Semi-automatic mode operation — procedure:

1. Press **F2** and use **+/-** key, select semi-automatic operation. Confirm your choice with **Enter**.
2. Press **Auto/Man** button. When the diode next to **Auto/Man** button lights up green, the wrapper operates in the automatic mode. The following message should appear on display:
Auto. Załadunek Wciśnij START
Pressing this button again deactivates automatic mode (after the LED goes out).
3. Drive the wrapper up to a bale. Start loading if the diodes over buttons 2, 3, 4 are lit green and turntable is in home position.
4. Press **Start/Stop** button to start automatic loading of bale. The following message is displayed after the operation is completed:
Auto. Owijanie Wciśnij START
5. Press **Start/Stop** button to start automatic wrapping. You can start driving to the next bale during wrapping. The following message is displayed after the operation is completed:
Auto. Rozładunek Wciśnij START
6. Now you can press **Start/Stop** to automatically unload or to drive to the next unwrapped bale with a wrapped bale located on the turntable and press  and  to grip and lift another bale with loading arm. The program will prevent manual loading of another bale but it will be possible to lift it sufficiently to drive to another, third unwrapped bale.
7. After reaching the third bale, automatically unload the wrapped bale using **Start/Stop** button.
8. When the unloading is completed, one complete bale is registered. Pressing **Start/Stop** again will start loading of a bale placed on the loading arm.
9. After the loading is complete, confirm the start of wrapping.
10. After the completion of wrapping, drive the wrapper away from the unloaded bale and confirm automatic unloading.
11. After unloading the second wrapped bale, confirm the loading of the third bale.
12. Start automatic wrapping after loading.
13. Next, drive away from the second unloaded bale and confirm the automatic unloading of the third wrapped bale.

Perform the actions from items 3 to 13 to wrap the next bales.



This system results in the production of three wrapped bales placed next to each other. This in turn facilitates loading of bales from the field.

4.2.6 Automatic operation

The difference between the automatic and semi-automatic mode is that no confirmation after the automatic loading is completed is necessary to start wrapping. The wrapping starts automatically after the loading arm is lowered.

The user's confirmation of unloading is always required. This is due to safety reasons in order to avoid unloading a bale in an incorrect place.

Automatic operation — procedure:

1. Press **F2** and use **+/-** keys to select automatic operation. Confirm your choice with **Enter**.
2. Press **Auto/Man** button. When the diode next to **Auto/Man** button lights up green, the wrapper operates in the automatic mode. The following message should appear on display:
Auto. Załadunek Wciśnij START
Pressing this button again deactivates automatic mode (after the LED goes out).
3. Drive the wrapper up to a bale. Start loading if the diodes over buttons 2, 3, 4 are lit green and turntable is in home position.
4. Press **Start/Stop** button to start automatic loading of bale. The wrapping starts automatically after loading operation is completed. The following message is displayed after the operation is completed:
Auto. Rozładunek Wciśnij START
5. Now you can press **Start/Stop** to automatically unload or to drive to the next unwrapped bale with a wrapped bale located on the turntable and press  and  to grip and lift another bale with loading arm. The program will prevent manual loading of another bale but it will be possible to lift it sufficiently to drive to another, third unwrapped bale.
6. After reaching the third bale, automatically unload the wrapped bale using **Start/Stop** button.
7. When the unloading is completed, one complete bale is registered. Pressing **Start/Stop** again will start loading and wrapping of a bale placed on the loading arm.
8. After the completion of wrapping, drive the wrapper away from the unloaded bale and confirm automatic unloading.
9. After unloading the second wrapped bale, confirm the automatic loading and wrapping of the third bale.
10. Next, drive away from the second unloaded bale and confirm the automatic unloading of the third wrapped bale.

4.2.7 Transport position

The wrapper's transport position enables the used to safely drive the tractor with the machine on public roads. When the wrapper is placed in transport position the machine elements are positioned as follows: front loading arm lifted to maximum, lifted and secured bale on end kit and bale on end kit's support stand retracted. The wrapper's drawbar in transport position. Due to that the machine's dimensions are reduced and it is easier to transport on public roads.

To set the wrapper in transport position:

1. Fully retract the bale on end kit's support and secure it with protective pins.
2. Manually tip the turntable to install transport locking device which prevents lowering the bale on end kit.

3. Install the locking device and secure it with pins.
4. Press **F2** (automatic mode must be off).
5. Press +/- buttons to select mode: **Tryb Pracy Poz. Transportowa**.
6. Confirm your choice with **Enter**.
7. After installing the locking device, lower the turntable again by holding turntable lowering button until the bale on end kit's support is lifted.
8. Lift the loading arm to the top position.
9. Set the drawbar to transport position.

Caution!

Do not move the turntable in transport position to prevent the table from hitting the bale on end kit's frame.

Caution!

In the transport position, the solenoid valve controlling the table return function does not deactivate after limit switch is activated by the element on the turntable's tipping frame. It deactivates after the release of table return button . This is the intended operation in order to enable lifting the bale on end kit's support stand.

Caution!

The loading arm's actuator is equipped with a safety valve to prevent the arm from lowering caused by the arm's weight. Still it is recommended to avoid the area near the loading arm during the transport of wrapper. It is recommended to lower the loading arm for the period of wrapper storage.

4.2.8 Stop during wrapping

Press **Start/Stop** during a wrapping operation in automatic/semi-automatic mode to stop the machine. This will deactivate the automatic mode and stop the moving units (the arm stopped during loading, turntable stopped during wrapping, turntable's tipping frame during unloading).

To avoid the repeated automatic loading with a bale already placed on the turntable or to avoid repeated wrapping of an already wrapped bale, you can choose the type of activity to start again during an active automatic mode. Perform the following action before starting the process if automatic mode is active:

1. Press F2 (when the diode next to Auto/Man button lights up green).
2. Select one of the three operations with +/- keys:
 - **Rozpocznij od Auto. Załadunek**
 - **Rozpocznij od Auto. Owijanie**
 - **Rozpocznij od Auto. Rozładunek**
3. Confirm your choice with **Enter**.
4. Press **Start/Stop** button to start.

The wrapper will start by performing the selected action and after completing the cycle (placing a bale on end), it will perform automatic loading.

4.2.9 Emergency stop

Should a failure occur during the operation of the wrapper or a situation which might endanger the operation of the wrapper, stop the machine by pressing  on the control panel, switch off the power supply to power hydraulic system, stop the tractor's engine and apply parking brake. Pressing STOP on the control panel deactivates power supply to the wrapper control unit. The LEDs on the panel blink red. All activities being performed by the wrapper will be stopped. The panel buttons are deactivated and moving any machine units is impossible.

After repairing the fault or eliminating danger, resume work by unlocking the panel by pressing



and



simultaneously or by switching the panel on and off.

5 Ongoing adjustments

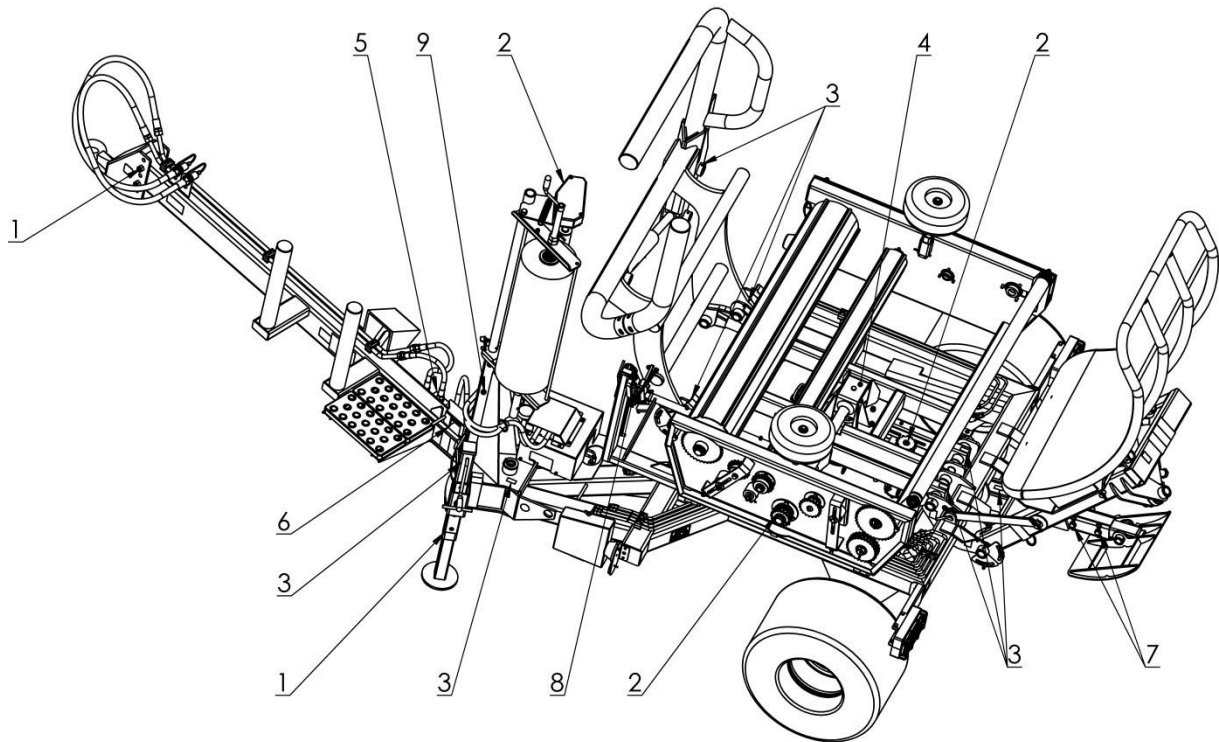

Fig. 9 Location of ongoing adjustment points

- Levelling of the bale wrapper during coupling with the tractor Item 1
- Chain tension item 2
- Lubrication points marked on the machine item 3
- Intersecting axis gear item 4
- Flow controller item 5
- Drawbar lock item 6
- Bale on end kit support stand item 7
- Film cutter item 8
- Film feeder, adjustable turn angle item 9

Locations of sensors is marked on the machine and in fig. 10, chapter 5.1.

Locations of check throttle valve are shown in fig. 13, chapter 5.3.

5.1 Correcting sensor settings

Wrapper sensors (10 pcs. in a wrapper) are more prone to damages and they are mainly responsible for safe operation. Replace faulty sensors. The operation range of sensors is from 1 to 5 mm. If you correct the distance between the sensor and actuator, keep approx. 3 mm gap. Do not allow direct contact of the tip of the sensor with actuator or other metal parts of the machine.

Caution!

Correct the sensor positions with the tractor's hydraulic system switched off and deactivated parking brake.

The sensors should activate when actuators reach their limit positions. A diode at the end of a sensor lights up when the sensor is activated (control panel must be active). Sensors under the turntable should activate when the activator's bolt head is located directly above the sensor.

Adjust the sensor responsible for counting revolutions and stopping the turntable (Fig. 10 item 5) when the turntable is positioned in parallel to the front beam of main frame. The activator's bolt head shall be placed approx. 5-10 mm to the right of the sensor. This is due to the inertia of turntable with a bale. If the sensor activated when the turntable is placed in parallel to frame, the brake response time would lead to an incorrect stop position. In such a situation, manually perform a free turn of the turntable and stop it at the correct position.

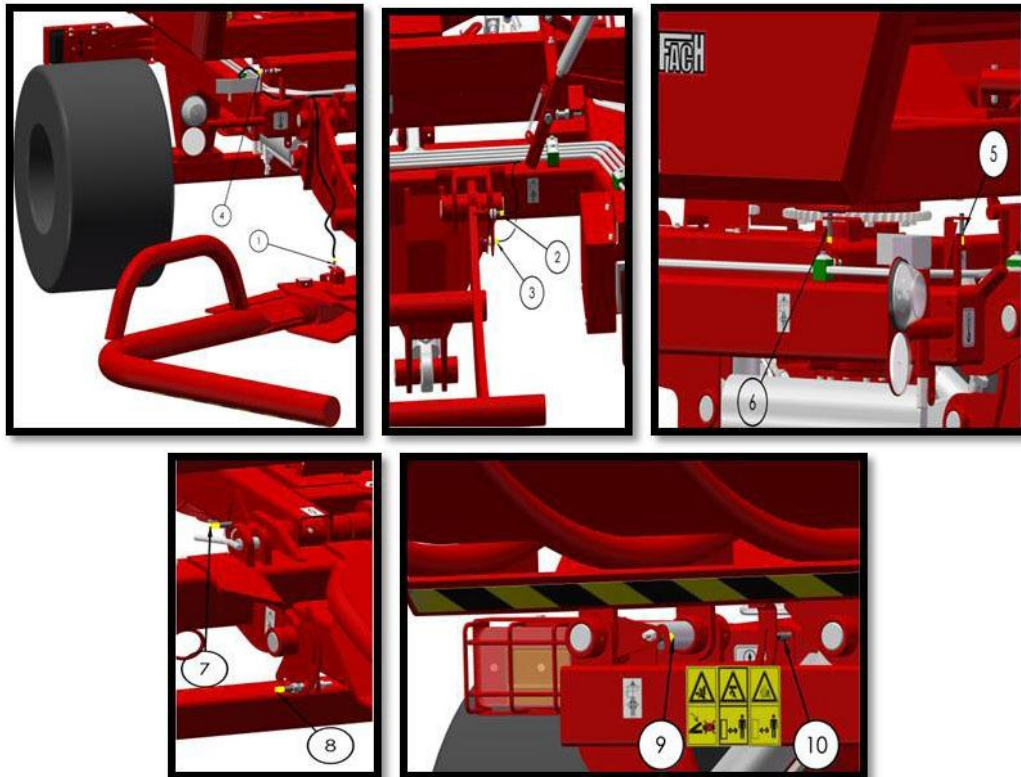

Fig. 10. Location of induction sensors.

- Maximum opening of loading arm sensor item 1
- Maximum lifting of loading arm sensor item 2
- Intermediate lifting of loading arm sensor item 3
- Turntable frame lowering sensor item 4
- Turntable revolutions counter and stop position sensor item 5
- Turntable slow down at the last revolution sensor item 6
- Turntable frame max. opening sensor item 7
- Bale on end kit frame position sensor item 8
- Bale on end kit's cradle home position sensor item 9
- Bale on end kit's cradle tipped position sensor item 10

5.2 Adjustment of bale on end kit support

The bale on end kit's support is height-adjustable to enable the adjustment of the level from which a bale is placed. Four settings of support's arm extension are available. Extending the support increases the height at which a bale is placed on end, retracting the support decreases the height.

To perform adjustment, remove keys from both key bolts and remove the bolts from the support frame. Next, extend the support to the desired length and secure it with key bolts (fig. 11).

During automatic unloading, if the bale on end kit's frame stops after unloading position sensor (fig. item 8) reaches its activator on the frame, and then the cradle is automatically tipped, it means that the sensor is adjusted correctly. If not, it is necessary to correct the adjustment of the unloading position sensor on the bale on end kit's frame (Fig. 12). To do that:

1. Manually tip the turntable frame by pressing .
2. Next, press  to lower the bale on end kit's arm to the lowest position and release the lowering button after reaching this position.
3. Turn off the tractor's hydraulic power supply system, stop the tractor's engine and engage the tractor parking brake. Do not switch off the control panel.
4. Loosen the fixing nuts of the unloading position sensor of the bale on end kit's frame.
5. Move the sensor to the position opposite the head of the sensor's activator bolt.
6. Place the sensor at the distance of approx. 3 mm from the activator's bolt head. The sensor LED should light up. This means that the sensor is activated by the activator.
7. Tighten the sensor's nuts to secure the sensor in the correct position.
8. Press  to lower the table.
9. In the automatic mode, select **Rozpocznij Auto. Rozładunek** (Start auto. unloading) and check if the setting is correct.

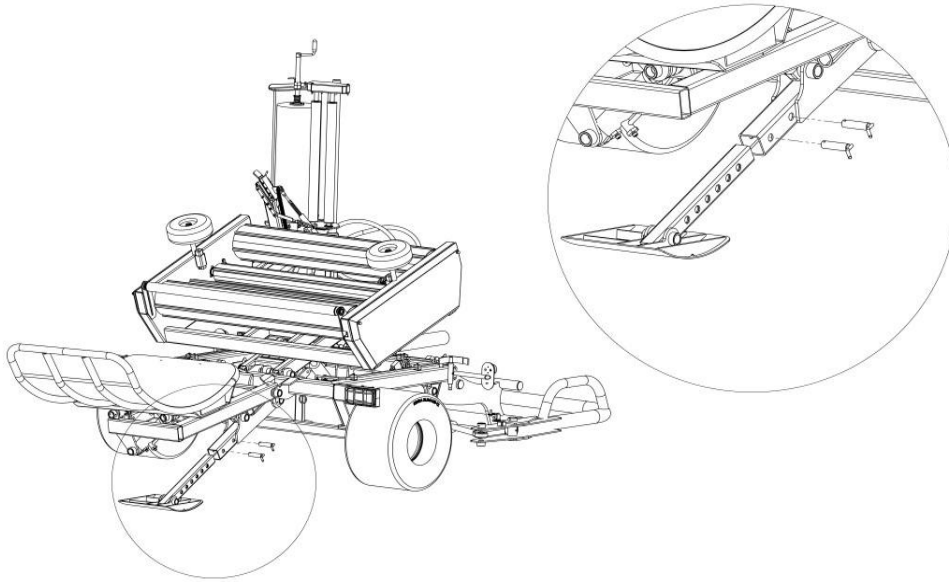

Fig. 11. Adjustment of bale on end kit's support extension.

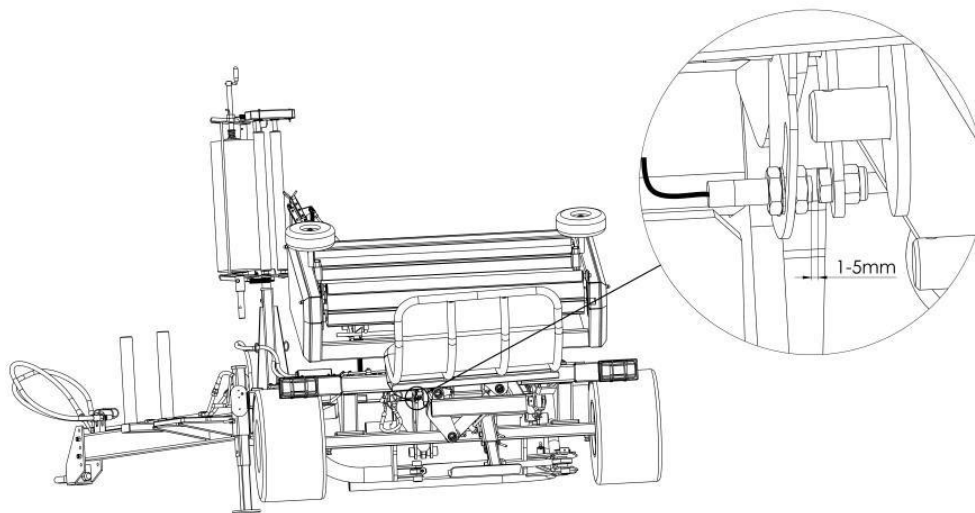

Fig. 12. Correcting the adjustment of the unloading position sensor on the bale on end kit's frame.

5.3 Adjustable hydraulic valves

Throttle check valves are installed in the wrapper's hydraulic system. Do not change the factory-settings of the valves without consulting a service centre or manufacturer.

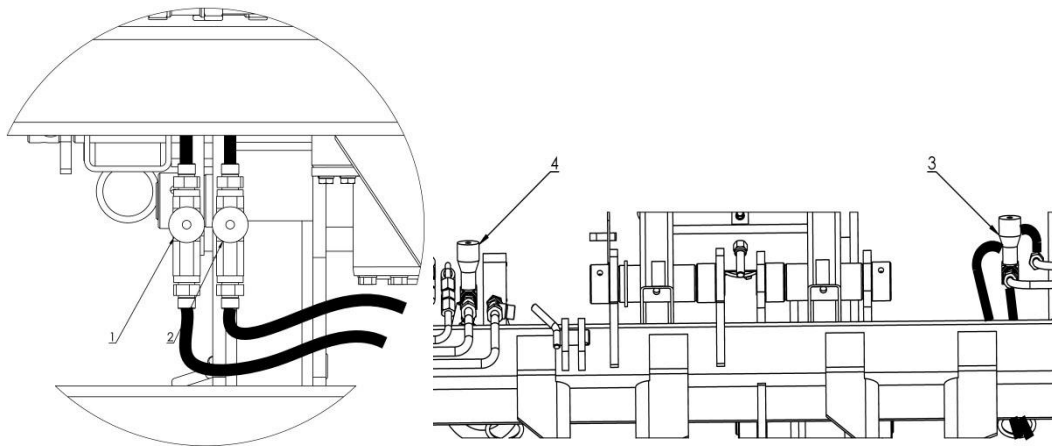

Fig. 13. Location of check-throttle valves.

Two check-throttle valves (fig. 13, items 1 and 2) controlling the unloading of the turntable are installed next to the actuator for lifting and lowering the wrapper's turntable during the bale unloading. They allow for a setting ensuring smooth movements of the rotary frame and bale unloading unit.

The check throttle valve (Fig. 13, item 3) installed at the back of the main frame at the return path of the bale unloading system's actuator which is responsible for smooth lowering of a bale being unloaded on the bale on end kit.

The check throttle valve (Fig. 13, item 4) is responsible for releasing pressure from the hydraulic engine braking at the moment of the turntable movement.

Flow regulator on the engine power supply line is factory-set. The regulator's settings may be performed by the service center during start-up of the machine by the dealer's service man. This device controls the maximum oil volume output in the wrapper supply system. Unauthorized modification of the regulator's factory setpoint may result in malfunction of the turntable. The correct setpoint range for the flow regulator is between 6 and 7 on the regulator's knob scale; it refers to the maximum output of 25 l/min according to the manufacturer's specification.

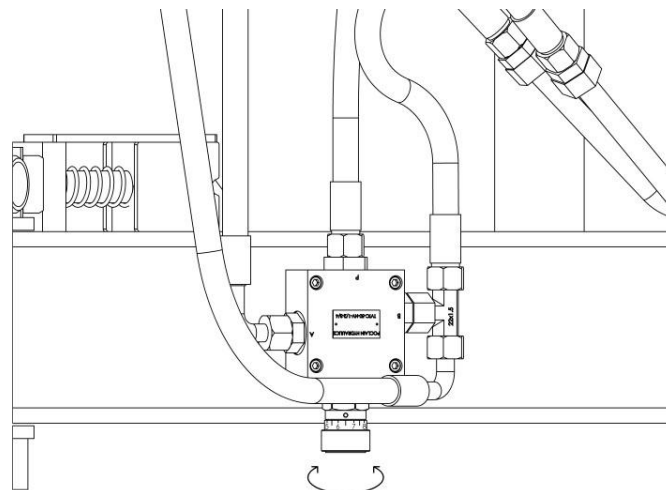

Fig. 14. Flow controller.

5.4 Towbar position change

The wrapper's towbar may be positioned in one of the three levels (Fig. 15):

- Working item A
- Medium item B
- Transport item C

The towbar position shall be adjusted after coupling with the tractor's transport hitch.

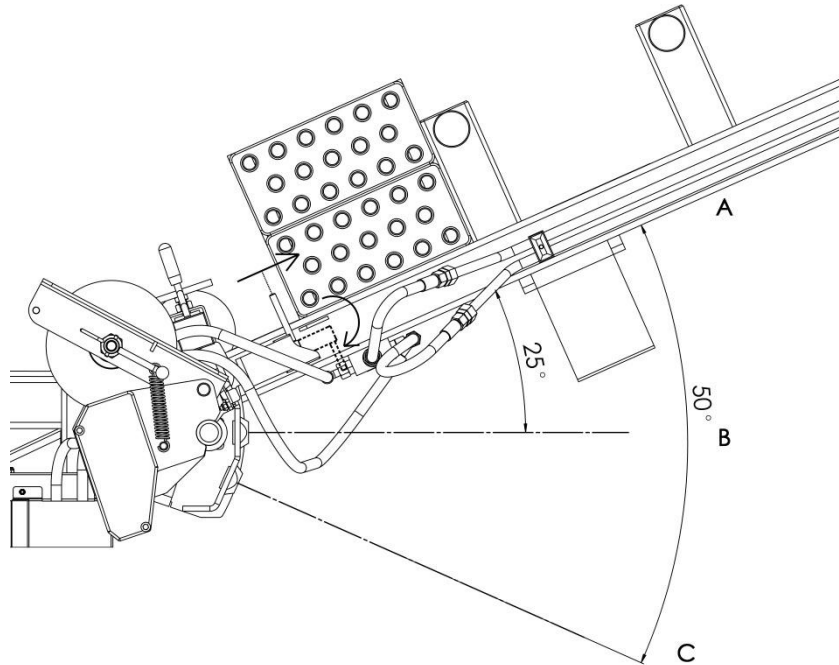

Fig. 15. Towbar position change

To change the towbar position:

- Align the coupled bale wrapper with the tractor axis,
- Pull the drawbar's locking pin (Fig. 15),
- Lock the right land wheel of the wrapper with a wedge,
- Slowly start driving the tractor coupled with a wrapper:
 - towards front, if you want to move the drawbar to working position,
 - backwards if you want to move the drawbar to transport position,until the locking pin is placed in the axis of the bushing for the selected position.
- Lock the drawbar in position with the locking pin.

Caution!

Be careful while changing the position of the drawbar. There is a risk of the operator's hand being crushed.

5.5 Installing film

Place the film roll on the feeder pin in the following order:

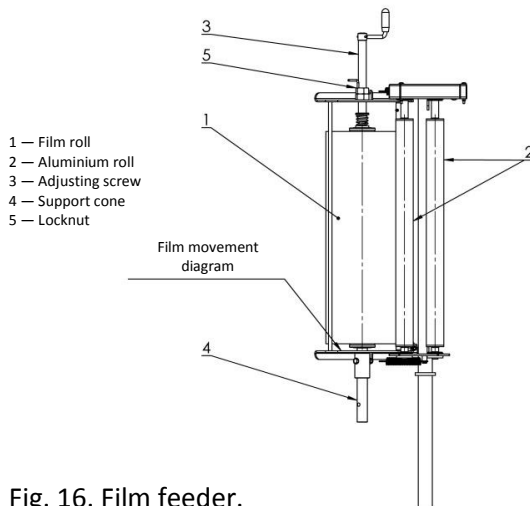

Fig. 16. Film feeder.

- Open the film support frame and secure with a hook placed on the wrapping unit.
- Using a lever (crank) undo the upper pin pressing the film upwards.
- Set the lower clamp to the correct width for the film roll width (500 mm or 750 mm),
- Place a film roll on the bottom conical clamp,
- Clamp the roll by turning the lever (crank) to move the top bolt on the conical clamp to ensure stable vertical hold of the film roll and to enable revolutions,
- Use the nut on the crank bolt to secure the film clamp bolt against inadvertent unlocking,
- When installing the roll of film, place its internal, sticky side towards the bale axis.
- Set the correct preliminary film tension,
- Pull the film and place it correctly on the rollers as shown on the diagram placed at film feeder's frame.
- Pull the film end to enable free grabbing and movement of the film.
- Adjust angle of revolution of film feeder unit in relation to film cutter.

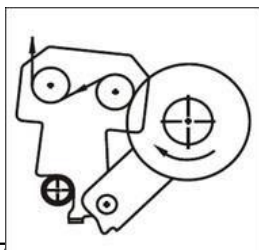
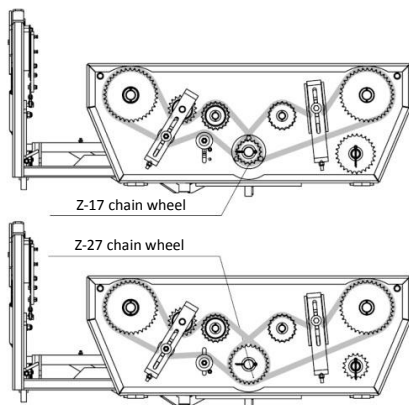

Fig. 17. Film movement diagram.

With every revolution of the frame, a bale with film moves by a certain angle on the horizontal axis which results in applying of consecutive layers of film to tightly wrap the bale.

The wrapper is pre-set to use 750 mm film. Change chain wheels to use 500 mm wide film (Fig. 18). To do so:



- Unscrew 2x M12 hub nuts, remove the side guard of the rotary frame (from the chain transmission side).
- Loosen the M12 screw on the chain stretcher.
- Remove the chain from the Z-27 chain wheel installed on the main shaft and remove the split pin securing the wheel.
- Remove the Z-27 chain wheel from the shaft (using an appropriate tool).
- Remove the Z-17 wheel from the spare chain wheel axis (bottom right corner of the turntable) and replace it with Z-27 chain wheel and secure with pin,
- Install the Z-17 chain wheel on the top shaft.
- Secure the Z-17 wheel with a cotter pin, install chain and adjust the tension. Place the guard.

Fig. 18. Changing gear ratio.

5.6 Adjustment of driving chain

Two chain transmissions are used in this bale wrapper. Adjust the tension of driving chains after wrapping the first 10 bales. Adjust the turntable drive chains tension using stretchers installed on the reels.

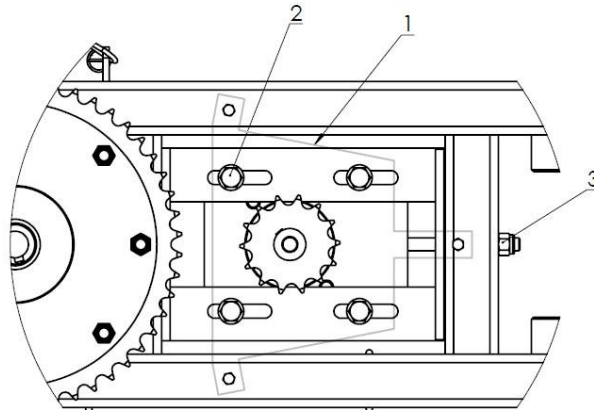

Fig. 19. Adjustment of turntable's driving chain.

Adjustment of turntable's driving chain (Fig. 19):

- Remove the chain cover (item 1),
- Loosen 4 M12 nuts (item 2),
- Tighten the M12 nut of chain tensioner (item 3) to obtain chain tension with 20 mm deflection,
- Tighten the 4 M12 screws (item 2).
- Install the chain guard.

Check the tightening and the chain condition periodically after wrapping every 120 bales.

5.7 Film cutter

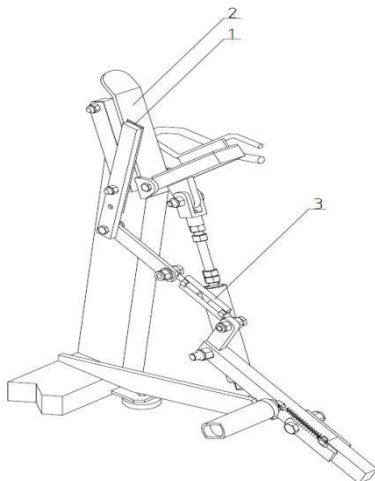

Fig. 20. Film cutter.

If the film cutter fails to operate correctly (Fig. 20), stop the wrapper, turn off the tractor engine, remove the ignition key and engage the tractor parking brake. Adjust the angle of inclination of the cutting blade (item 1) in relation to film in the clamp (item 2). Adjust with the tensioning bolt (item 3). Turn the tightening bolt clockwise to decrease the blade angle of inclination in relation to film and counterclockwise to increase the angle.

A correctly adjusted blade cuts tensioned film when it is caught by clamp during the placement of a bale on the ground.

Cutting surfaces of a moving and stationary blade in the locked position (film is cut and being held) should adhere to each other. If necessary, adjust the pressure of these elements against each other using moving blade tensioning bolts.

When the angle is too steep, the film is not cut even though the bale is unloaded to the ground.

Caution!

Take extra caution when adjusting the cutter. The cutter is extremely sharp. Danger of hand injury.

The wheels installed on the sides of the moving frame protect a bale against sliding off reels during wrapping.

6 Wrapping

6.1 Wrapper preparation

Perform the following to prepare the wrapper for work:

- Couple the wrapper to the tractor's lower hitch, level the wrapper (chapter 2.1), check the correct coupling,
- Connect electric power supply (lights, control panel power and control panel itself) and connect hydraulic cables to the tractor's hydraulic system (chapter 2.1), check the correct connections,
- Set the drawbar in working position (chapter 5.3),
- Remove the protective device from the bale on end kit arm,
- Switch on the control panel and check the correct operation of power hydraulic systems without bale and without film in manual mode (chapters 2.1 and 4.2),
- Check the correct operation of power hydraulic systems without bale and without film in semi-automatic mode (chapters 2.1 and 4.2).

6.2 Bale loading

Using the wrapper movement control buttons on the control panel, manually position the loading arm, turntable, bale on end kit and wrapper's cradle in home positions (chapters 4.2.1 and 4.2.2). Select automatic or semi-automatic mode and press **Auto/Man** to activate automatic operation of the wrapper. Drive up to a bale as described below.

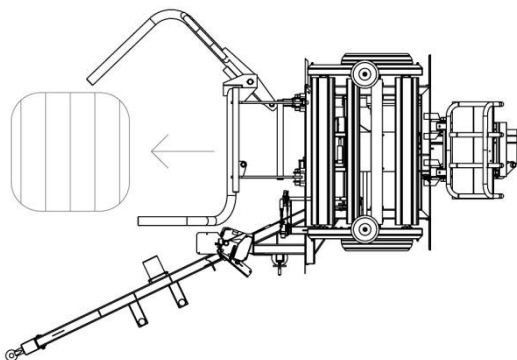

Fig. 21. Driving to bale.

The axis of the approaching wrapper should be perpendicular to the axis of a bale being loaded and the arm after lowering should grab the bale.

Stop the tractor when the bale leans against the loading arm's area.

Press Start/Stop to activate automatic bale loading (chapters 4.2.5 and 4.2.6).

If you are not sure if the tilted bale lands correctly on the turntable, perform manual loading using the loading arm's control buttons. You will be able to lower the loading arm with a bale inside, correct the tractor's position and catch and load the bale again.

Every repeated loading will be performed automatically after pressing **Start/Stop**.

You can move the loading arm before or after wrapping. Due to safety reasons, it is impossible to move the arm during wrapping itself.

6.3 Wrapping

Caution!

Before commencing wrapping, make sure that there are no bystanders, especially children, near wrapper.

Make sure that a bale placed on turntable lays evenly on the table's reels.

Confirm the start of semi-automatic wrapping by pressing **Start/Stop**.

If automatic mode is activated, wrapping will commence immediately after a bale is placed on the turntable and loading arm is lowered. Beginning users are recommended to use semi-automatic mode which requires confirmation before starting wrapping. To use automatic mode, you should be proficient in correct approaching bales with tractor and grabbing them with loading arm.

The bales should be wrapped only at positive temperatures. The bales should be wrapped in a field or in their storage area. By avoiding unnecessary transport of bales, the risk of the wrapping film being damaged is minimised.

Pay particular attention to the correct preliminary film tension (65-85%)¹. A worn-out or unlubricated clamp may result in wrapping the film too tight or too weak. The film tension must not exceed 70%.

Pull the film at the first bale as far as possible from the feeder and attach it using the string binding the bale. If you are using net for wrapping, manually move away the cutter's arms by pushing the cutter lever down (located between the two front reels). Install film in holder and pull lever to close the cutter's arms.

Caution!

Take extra caution when installing film. The cutter blade is extremely sharp. Danger of cuts to hands. Before installing film in cutter, turn off the tractor's engine, remove the ignition key and engage the tractor parking brake.

¹*Mark two vertical lines at the distance of 10 cm on the roll. The distance of 17 cm between the lines represents 70% of initial film tension. The film width measured at the end of reel shall not be smaller than 400 mm for 500 mm wide film and smaller than 600 mm for 750 mm wide film.*

While placed on the rotary table, the bale is rotated by a certain angle around its horizontal axis with every revolution around its vertical axis, which causes overlapping of consecutive layers of film resulting in a tight wrap around the bale. A correctly wrapped bale has at least 4 layers of film on cylindrical walls of bale with 50% overlap.

The recommended number of wraps for 500 mm wide film is 24 revolutions of the turntable and 16 revolutions for 750 mm wide film.

Caution!

Keeping the rollers and their edges in good condition minimizes the risk of ripping the film during wrapping.

Do not perform wrapping during rain.

If the bale is wrapped too tightly, halt the wrapping process. Establish the cause of excess film tension. Set the proper film tension. Resume the wrapping process.

Wrapped bales should be used within 12 months from wrapping date.

6.4 Unloading a wrapped bale

Turntable stops automatically in an unloading position after wrapping is complete. When the position of the turntable is correct, the film cutter arm is located in front of the wrapper, table's reels are placed in parallel to the wrapper's frame front beams and side covers are placed in parallel to the driving axle. If the table has been stopped in another position, use the turntable free movement buttons on the control panel to correct the table position.

Caution!

Before unloading, make sure that no bystanders, especially children are present near the unloading zone and check if it is safe to unload.

Press **Start/Stop** after a completed wrapping cycle to unload.

During unloading, the turntable containing a bale is raised and bale on end kit's arm is also raised as shown below.



Fig. 22. Unloading of a bale to the bale on end kit's cradle. The figures next to arrows show the correct order of movements of working units during unloading.

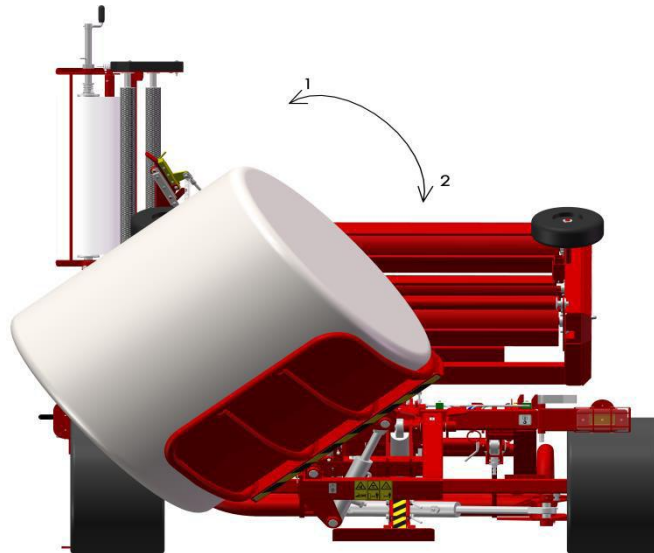

Fig. 23. Unloading a bale on the ground. The figures next to arrows show the order of movements of bale on end kit's cradle.

All working units should return to their home positions after completing bale unloading. Another bale may now be loaded.

6.5 Finishing work

After finishing work, unplug the control panel and protect it against damage from falling or humidity.

In case of a longer standstill of a wrapper, remove the control module and place it in a dry storage.

Place the machine on a hard, flat, level ground. Disconnect the hydraulic power source and the electric power supply.

Support the drawbar using a support stand.

Disconnect the wrapper's drawbar from the tractor's transport hitch.

Caution!

Do not uncouple a wrapper with a bale on the turntable.

Clean the machine and check its condition, paying special attention to the quality of the paint coat. If it is required to make some touch-ups, it is advised to use the paint repair kit supplied by the manufacturer.

Caution!

Do not clean the wrapper with high-pressure washers. This may damage electric harness.

Protect the rubber elements, i.e. hydraulic lines, ground wheels against direct sunlight.

7 Periodical inspections

7.1 User inspection

After every use of the bale wrapper, check:

- The condition and legibility of the nameplate and pictograms;
- Condition of the machine drawbar elements;
- Tightness of the hydraulic system;
- Driving chain of the rotary frame;
- Driving chains of the rotary drums.
- The nameplate must only be replaced at an authorised service point.
- Replace the illegible pictograms with new ones.

After closing the working season, apply bearing grease, e.g. ŁT-43 to driving chain of the rotary frame and to driving chains of rotary reels.

If the control panel's body is damaged, have it repaired by an authorised service point. Unauthorised repair of the control panel voids the panel's warranty.

- Replace the oil of the intersecting axis gear every 2 years as follows:
- Place the machine on a level surface.
- Place a leak proof tank below the drain plug.
- Remove the drain plug, the filler plug and the overflow plug,
- After the oil is drained, close the drain plug,
- Pour fresh 80W90 hydraulic gear oil to the filler plug level,
- Close the filler plug and overflow plug.

The used oil should be sent to a petrol station which collects such products.

Caution!

During oil replacement, it is required to wear impermeable protective clothing suitable for contact with oil-based products.

Caution!

Do not mix different types of hydraulic oils. Check oil filter after first start-up and every 12 hours of work. Metal filings in the filter's housing show that the power supply is overloaded (tractor's hydraulic system). Stop wrapper.

Replace the power hydraulic lines every 5 years. Before every working season, check (without a silage bale loaded) the operation of the transmission system by turning on the rotary table, raising and lowering the rotary table and raising and lowering the loading unit, and raising and lowering the unloading unit.

Clean the soiled control panel's body with a slightly moist cloth with detergent. Do not use organic thinners (acetone, petrol, paint thinner, etc.) as they might damage the panel's body.

7.2 Service checks

Periodical service checks shall be performed after every two working seasons of machine use.

It is advised to use original spare parts which will help maintain the wrapping machine in a good technical order for a long time.

8 Authorised service

8.1 Warranty service

The manufacturer issues a warranty on conditions described in the warranty card. During the period covered by the warranty, repairs shall be made at authorised service stations or at the manufacturer's service point.

8.2 Ongoing maintenance

After the period covered by the warranty it is advised to perform periodical inspections, adjustments and repairs at authorised outlets service stations.

8.3 Ordering spare parts

Spare parts should be ordered from resellers or directly from the manufacturer stating the name and surname of the user or company name and address, name, symbol, serial number and year of manufacture of the machine, catalogue name of the part, catalogue number, number of a drawing or standard, number of ordered items and agreed terms of payment.

9 Transporting the bale wrapper

9.1 Transporting a load

The bale wrapper is suitable for road and rail transport using carriers with appropriate load bearing capacity.

Caution!

For loading on a means of railway transport, use lifting devices with a lifting capacity appropriate for the machine weight including a loaded roll of film. Use the frame elements marked on the machine as attachment points (see the symbol below).



Fig. 24. Attachment points for loading on a means of transport.

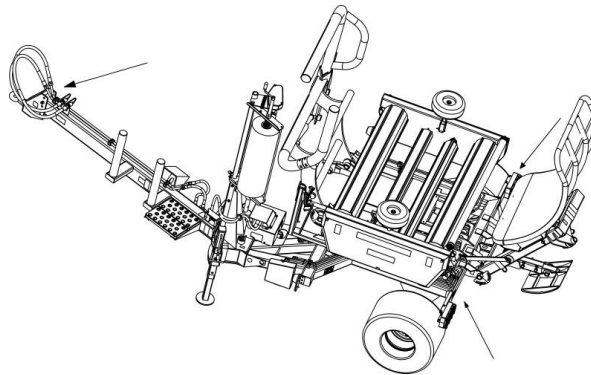

Fig. 25. Location of attachment points on the wrapper.

The lifting device should be operated by experienced operators with appropriate qualifications.

It is forbidden to transport a wrapper with bales of silage.

The transported wrapper must be securely fastened to the carrier vehicle.

9.2 Driving on public roads

The bale wrapper machine may be used on public roads as a machine attached to a tractor transport hitch.

The dimensions of the machine prepared for transport are given in chapter 1.5.

For transporting the machine on public roads, tractors with a rated power not lower than 30 kW and towing power class not lower than 0,9 equipped with a transport hitch may be used.

Before entering a public road:

- Place the hitch in transport position (chapter 5.4),
- Position the rotary frame so that the reels are placed perpendicularly to the wrapper's axis (and driving axis),
- Lift the loading arm to the max,
- Lock the bale lowering arm in the top position using protective device (Fig. 26, chapter 4.2.7),
- Disconnect and properly secure the hydraulic lines,
- Connect the wrapper lights to the tractor's power supply socket and check the correct operation of the lights,
- Leave the wrapper's control panel in the tractor's cab,
- Place the triangle denoting slow-running vehicles in the stand in the rear grip,

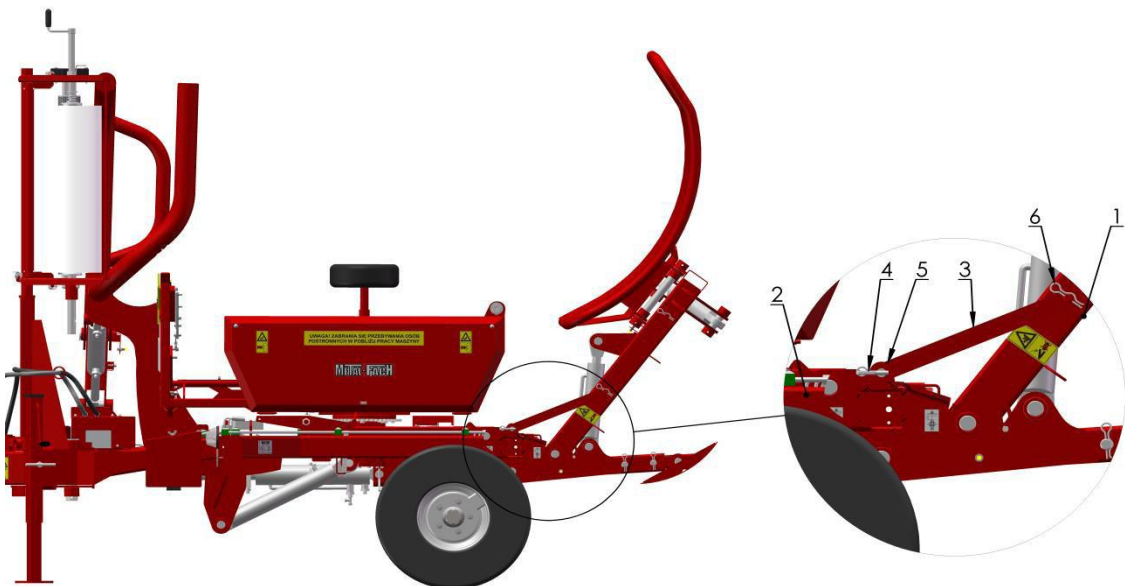

Fig. 26. Bale on end kit's frame protective device. 1-Kit frame, 2-Main frame, 3-Protective bar, 4-Bar pin, 5-Bar installation eye, 6-Cotter pin.

Before every drive, starting the wrapper and driving on public roads, check the correctness of coupling of the machine with tractor, tightening of wheel bolts and correctness of tractor-hitch connection. Clean off the remains of silage to prevent from soiling roads.

It is forbidden to carry persons or bales of silage on the wrapper.

Before entering public roads, check if the tractor is fully steerable. The load on the front axle must be at least 20% of the tractor's own weight (chapter 2.1). If not, use extra weights.

While driving on public roads, the speed should be adjusted to the existing conditions and not exceeding 15 kph.

Follow the traffic code regulations when transporting the wrapping machine on public roads. If an emergency requires the driver to stop the tractor with a coupled bale wrapping machine, the tractor driver should:

stop the vehicle without causing any danger to the road users,

stop the vehicle as close to the road edge as possible and parallel to the road axis,

turn off the engine, remove the ignition key, engage the parking brake and place wedges under the wrapping machine wheels;

outside a built-up area, the warning triangle should be placed 30 - 50 meters behind the vehicle and the emergency lights must be turned on;

in a built-up area, turn on the emergency lights and place the warning triangle in the stand on the rear of the machine. Make sure that the triangle is visible to other road users,

In the event of a breakdown, take the required precautions to ensure safety in the area.

10 Bale wrapper storage

- Store the control panel in a dry place with terminals protected against dirt and humidity.
- Store the control panel's cable in a dry place with terminals protected against dirt and humidity.
- Store the wrapping machine on a hard, flat, level surface.
- It is advised to store the wrapping machine in a dry location, protecting it against UV rays and other harmful agents.
- If the wrapping machine is stored without any canopy roof, protect it with a water-resistant tarpaulin or film.

Caution!

Store the wrapping machine in an atmosphere free of aggressive agents (e.g. ammonia, chemicals).

- After the working season is over, clean the wrapping machine and check the condition of the protective paint coating. Touch up the damage to the paint coating at a service workshop.
- Check the condition and legibility of the nameplate. If the plate is damaged, notify the service station.
- Check the condition and legibility of the symbols. If they are damaged, replace them with new ones.

11 Hazards

11.1 Description of residual risk

Residual risk results from incorrect actions of the wrapping machine operator. The greatest hazards occur during the following forbidden actions:

- Installation of the wrapping machine on tractors which do not meet the required minimum criteria stated in this manual;
- Standing below raised components of the machine,
- Standing in the machine working area;
- Maintenance or repairs conducted with the tractor engine on;
- Machine operation by an operator standing outside the tractor cabin;
- Machine operation by an operator under influence of alcohol;
- Operating a wrapping machine which is damaged or without protective guards in place;
- Operating the wrapping machine on slopes with an inclination exceeding 8°;
- Carrying bales of silage on the wrapper during transport on public roads.
- Remaining on (aboard) the machine when it is working or during transport;
- Using the wrapping machine against its intended use;
- Leaving the bale wrapper unsecured on an inclined land,
- Standing between the tractor and the machine while the engine is running.

With the aforementioned residual risks, the bale wrapper is regarded as a machine which has been designed and built according to the current state of technology.

11.2 Assessment of residual risk

Follow these guidelines:

- Read and fully understand the Operating Manual.
- Do not stand below the raised lifting components of the machine.
- Do not stand in the machine working area.
- The maintenance and repairs of the wrapping machine should be performed at authorised service workshops.
- The machine should be used by trained and authorised operators.
- Protect the wrapping machine from access by children and bystanders.
- Only then can you eliminate the residual risks related to using this wrapping machine and keep it safe to people and the environment.

Caution!

The residual risks are present when the aforementioned manufacturer's rules and indications are not followed.

12 Bale wrapper disposal

Disassembly and disposal of the wrapping machine should be performed by specialised service stations familiarised with the construction and functioning of the machine. Only specialised service stations have a complete and up-to-date knowledge of the applied materials and hazards related to their improper transport and storage. The authorised service stations offer both advice and complete machine disposal services.

Use proper tools and auxiliary equipment for the disassembly (jack, lift, wheel extractor).

The used oil must be stored in sealed containers. Immediately dispose of the used oil at petrol stations which collect such materials.

Dismantle the machine. Segregate the dismantled components. Pass the dismantled components to relevant collection points.

During disassembly of the wrapping machine use proper protective clothing and shoes.

13 Typical problems and troubleshooting

No.	Problem	Reason	Remedy
I	II	III	IV
1.	Wrapper's hydraulic actuators work slowly or do not work at all. Turntable works unevenly, too fast or too slow.	Not enough oil in the tractor's hydraulic system.	Check the oil level in the tractor. Top up with oil.
		Pressure in the tractor hydraulic system is too low.	Check the tractor hydraulic system pressure.
		Incorrect setting of the wrapper's flow regulator.	Check the wrapper's flow regulator setpoint (5.3).
		Damaged actuator or hydraulic motor.	Replace the actuator or hydraulic motor.
		Incorrect setting of external circuit lever.	Turn on the pump drive.
2.	The wrapper works too slowly.	Not enough oil in the tractor's hydraulic system.	Check the oil level in the tractor. Top up with oil.
3.	Oil leaks from the control unit.	Worn out seal rings.	Replace the seal rings on the hydraulic control unit.
4.	Individual wrapping stages are not being completed in automatic and semi-automatic modes.	Induction sensors are placed incorrectly in relation to their activators.	Correct the positioning of induction sensors in relation to their activators (chapter 5.1).
		Sensor damage.	Replace a damaged sensor.
5.	No reaction to manual movement commands from control panel.	Lack of contact at electric connections of plugs on the control module.	Check the correct connection.
		Lack of contact at electric connections of plugs on solenoid valves of the hydraulic block.	
6.	The film edges cover too small or too much during bale wrapping.	Incorrectly installed chain wheel.	Replace with a proper chain wheel (chapter 5.5).

No.	Problem	Reason	Remedy
I	II	III	IV
7.	The film being cut is not stopped in the film cutter unit.	The rubber clamp holding the cut film is not adjusted properly.	Adjust the film clamp (chapter 5.7).
8.	Bale unloading problem. A bale tips on the side after placing on the ground.	The bale is released from a too high position.	Adjust the height of bale on end kit's support stand (chapter 5.2).
		Incorrect ground inclination.	Unload the wrapped bales on an even ground.

14 Accessories

The user may purchase the following optional and additional equipment at an authorised reseller or directly from the manufacturer:

- Spare parts catalogue - printed version.
- Warning triangles for slow-running vehicles,
- Chain wheel extractor
- Paint touch-up kit

15 Names and abbreviations

Nameplate – plate with information which unequivocally identifies the machine.

Symbol – information plate

OH&S – Occupational Health and Safety

Hitch, transport hitch – coupling elements of the tractor (see the tractor's operation manual).

UV – ultraviolet radiation; invisible electromagnetic radiation which may have a negative influence on human health; UV radiation also has a negative effect on rubber elements.

Towing class – a value of towing power of a given tractor, 0.9 class refer to towing power of 9 kN. Examples of tractors: Ursus C 355 and 4011.

kW – kilowatt, a unit of power.

V – volt, a unit of voltage.

bar – a unit of pressure (1 bar = 0.1 MPa)

m – meter, unit of distance

mm – millimetre, auxiliary unit of distance

min – minute, auxiliary unit of time equal to 60 seconds,

rev - revolution, type of movement

RPM – revolutions per minute, unit of rotational speed

kph – kilometres per hour, unit of speed,

db(A) – A-scale decibel, unit of acoustic pressure,



Bale wrapping machine warranty card

Metal-Fach
ul. Kresowa 62
16-100 Sokółka,
Poland

Warranty card
Z593-0E Bale wrappers
(filled out by the seller)

Serial no.:

Year/date of manufacture.....

Date of sale:

The warranty service is provided on behalf of the manufacturer by:

.....
(Seller's stamp, legible signature of the outlet representative)

Name and surname of the Customer Signature

Post code, City

Street, Tel. number

Warranty conditions

1. The manufacturer provides a bale wrapping machine designed and built in compliance with the current standards. The manufacturer guarantees that the supplied bale wrapping machine is free of manufacturing defects.
2. Metal-Fach Sp. z o.o. provides warranty service for 12 months starting from the date of first sale, provided the wrapping machine is used for its intended purpose and the recommendations contained in the manual are followed.
3. The warranty card properly filled in at the Outlet is the confirmation of the manufacturer's warranty; the acceptance of the warranty conditions must be confirmed with the customer's signature.
4. The quality warranty covers the machine defects caused by defective manufacturing, material defects and latent defects.
5. The warranty does not cover the assemblies and parts which are subject to normal wear and tear.

6. The warranty does not cover any mechanical damage or other damage resulting from improper use, improper maintenance or improper adjustment of the wrapping machine.
7. The warranty does not cover any damage resulting from improper storage of the machine.
8. Any unauthorised modifications in the construction of the machine introduced by the user will result in automatic termination of the warranty.
9. The manufacturer shall not be held responsible for loss, damage or destruction of the product resulting from causes other than defects of the supplied machine.
10. During the warranty period the manufacturer will repair any defects which occurred as a result of the manufacturer's negligence with the exception of defects listed in items from 5 to 8.
11. The warranty repair shall be made within 14 working days of the notification/supply of the wrapping machine to the designated service station or at another time agreed upon by the parties.
12. The warranty is extended by the time required to complete the repair.
13. During the warranty period all repairs which are not covered by the warranty are performed by authorised service stations at a full cost chargeable to the user. Before such repairs, the service station will inform the user of the suggested cost, time and scope of the repair.
14. The decision whether to commence a chargeable repair of the wrapping machine with a warranty valid at the time of repair is made by the customer.

Annex to the Operating Instructions:
EC DECLARATION OF CONFORMITY FOR THIS MACHINE
Z593-0E Self-loading bale wrapper

METAL-FACH Sp. z o.o.
ul. Kresowa 62
Phone no: 85 711 98 44
Fax: 85 7111 07 89
handel@metalfach.com.pl
www.metalfach.com.pl